

## Weatherstrip for Front Roof Frame, Replace

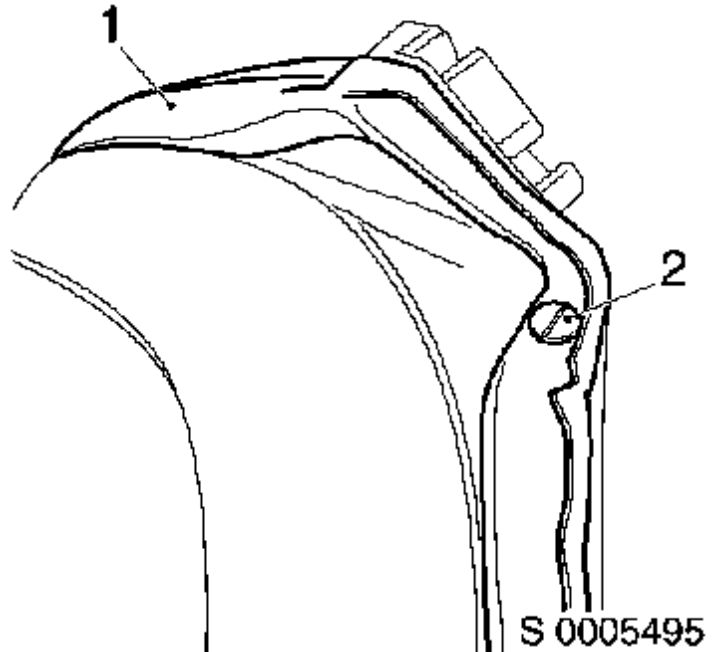

### Remove

1. Remove soft top or hard top
2. Remove weatherstrip (1)
  - Cut back head of 2x plastic retainer (2) flush with front roof frame on left side and right side
  - Note:** Visibly mark position of 2x plastic retainer for later reference.
  - Pull off weatherstrip



3. Remove all traces of adhesive residue



### Install

4. Apply masking tape to front roof frame on both top corners adjacent to soft top or hard top mounting brackets
  - Apply tape 200 mm each side of mounting bracket
  - Note:** This is for marking optimum position of weatherstrip location.
5. Prime adhesive area
  - Apply recommended primer to complete weatherstrip path
    - Allow to cure
6. Locate new weatherstrip and temporarily tape in position
7. Install soft top or hard top
8. Position weatherstrip to optimum sealing position
  - Mark position on previously applied masking tape
9. Remove soft top or hard top
10. Punch 2x 5 mm hole in weatherstrip for 2x plastic retainer
  - Note:** Punch holes should not conflict with position of old plastic retainers.
11. Partially remove protective tape from weatherstrip
  - Remove protective tape from S section (1) on left side and right side
  - Align weatherstrip to previously marked position and apply pressure

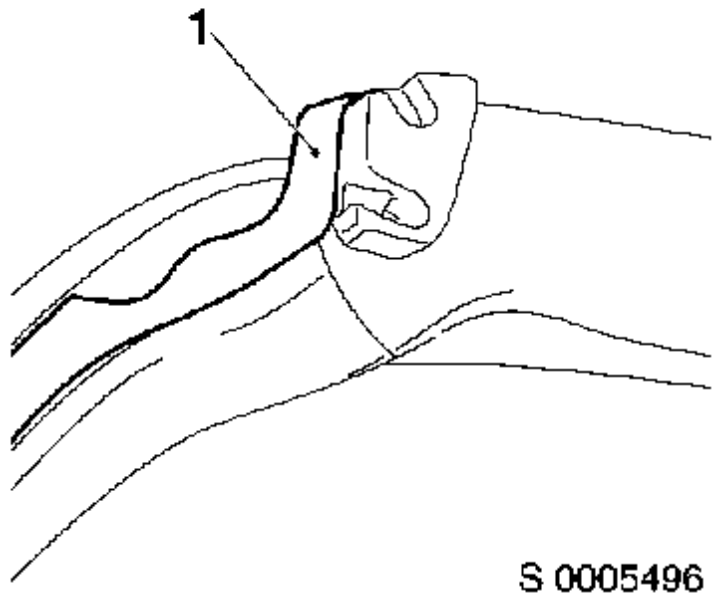

12. Secure weatherstrip to front roof frame between 2x soft top or hard top mounting brackets
- Remove protective tape, position weatherstrip then apply pressure

13. Secure weatherstrip to 2x A pillar
- Align front weatherstrip (1) with rear weatherstrip (2)
  - Remove protective tape, position weatherstrip then apply pressure

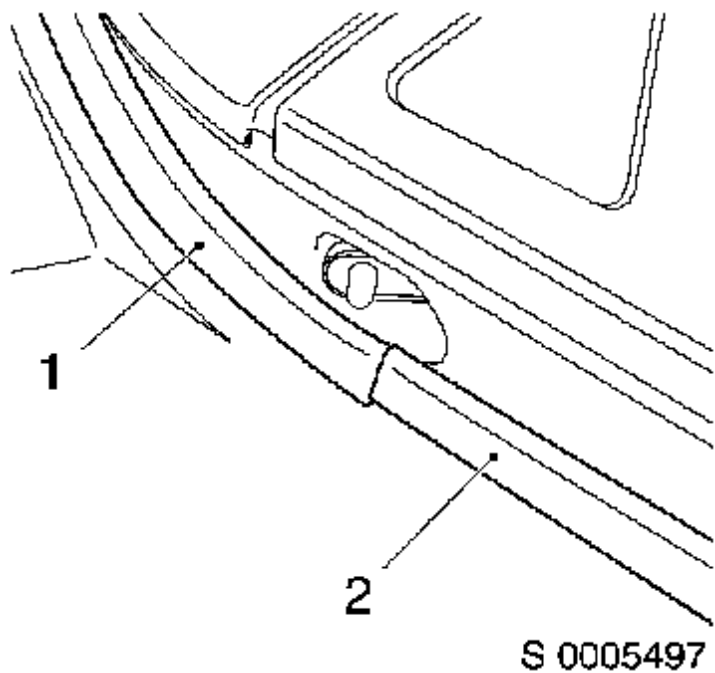

14. Apply recommended adhesive sealant between front roof frame (1) and weatherstrip (2)
- Note:** Apply adhesive sealant along seam where arrowed.

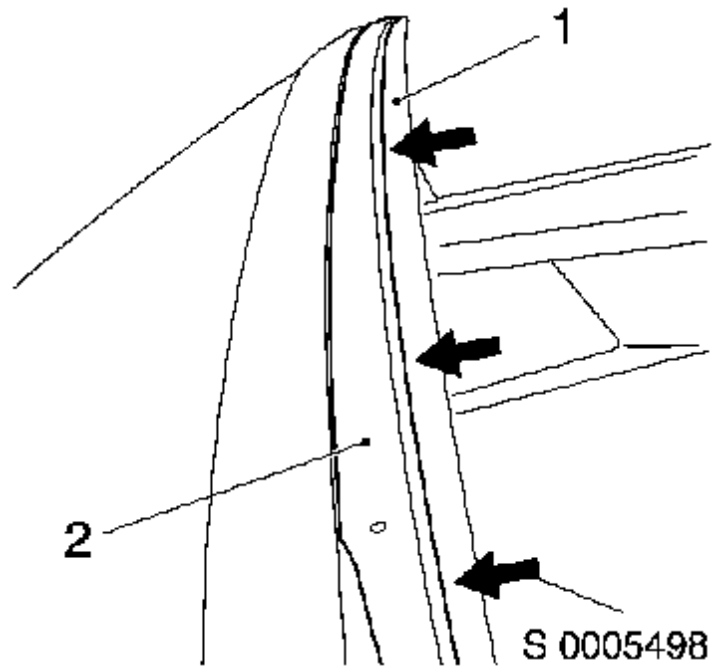

15. Drill 2x hole for 2x plastic retainer
  - Note position of 2x hole in weatherstrip
  - Use 5 mm drill
  - Drill to maximum depth of 8 mm
16. Install 2x new plastic retainers
  - Apply recommended adhesive sealant to 2x hole
17. Apply pressure evenly to weatherstrip, then allow to cure for a minimum of two hours
18. Install soft top or hard top